

SITI

SPA

SOCIETÀ ITALIANA TRASMISSIONI INDUSTRIALI



U - MU

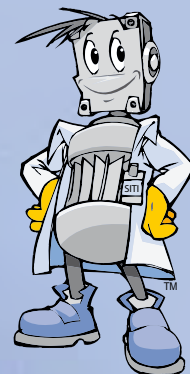

- IT** ACCESSORI
- EN** ACCESSOIRES
- DE** ZUBEHÖRE
- FR** ACCESSOIRES
- ES** ACCESORIOS
- PT** ACESSÓRIOS

ACCESSORI IT	ACCESSOIRES EN	ZUBEHÖRE DE
ACCESSORI A.2 ALBERO VELOCE BISPORGENTE A.2 ALBERO LENTO SEMPLICE/DOPPIO..... A.2 BRACCIO DI REAZIONE A.3 COPERCHIO DI PROTEZIONE A.3	ACCESSOIRES A.2 DOUBLE EXTENDED INPUT SHAFT A.2 SINGLE/DOUBLE OUTPUT SHAFT..... A.2 TORQUE ARM A.3 PROTECTIVE COVER A.3	ZUBEHÖRE A.2 DOPPELSEITIGE ANTRIEBSWELLE . A.2 EINSEITIGE / DOPPELSEITIGE AB- TRIEBSWELLE..... A.2 DREHMOMENTSTUTZEN A.3 SCHUTZABDECKUNG A.3
ACCESSOIRES FR	ACCESORIOS ES	ACESSÓRIOS PT
ACCESSOIRES A.2 ARBRE GRANDE VITESSE À DEUX BOUTS A.2 ARBRE PETITE VITESSE SIMPLE/ DOUBLE A.2 BRAS DE RÉACTION..... A.3 COUVERCLE DE PROTECTION A.3	ACCESORIOS A.2 EJE RÁPIDO DE DOBLE ENTRADA..... A.2 EJE LENTO SENCILLO/DOBLE A.2 BRAZO DE REACCION A.3 TAPA DE PROTECCIÓN..... A.3	ACESSÓRIOS A.2 EIXO DUPLO DE ENTRADA A.2 EIXO DE SAÍDA SIMPLES/DUPLO A.2 BRAÇO DE TRAÇÃO..... A.3 TAMPA DE PROTEÇÃO A.3

ACCESSORI IT	ACCESSOIRES EN	ZUBEHÖRE DE
ACCESSOIRES FR	ACCESORIOS ES	ACESSÓRIOS PT

ALBERO VELOCE BISPORGENTE IT	DOUBLE EXTENDED INPUT SHAFT EN	DOPPELSEITIGE ANTRIEBSWELLE DE
ARBRE GRANDE VITESSE À DEUX BOUTS FR	EJE RÁPIDO DE DOBLE ENTRADA ES	EIXO DUPLO DE ENTRADA PT

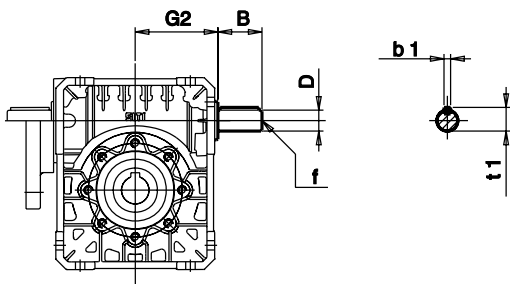

	G2	D (j6)	B	f	b1	t1
MU 30	51	9	20	M4	3	10,8
MU 40	53	11	23	M4	4	12,5
MU 50	64	14	30	M6	5	16
MU 63	75	19	40	M8	6	21,5
MU 75	90	24	50	M8	8	27
MU 90	108	24	50	M8	8	27
MU 110	135	28	60	M10	8	31

ALBERO LENTO SEMPLICE/DOPPIO IT	SINGLE/DOUBLE OUTPUT SHAFT EN	EINSEITIGE / DOPPELSEITIGE ABTRIEBSWELLE DE
ARBRE PETITE VITESSE SIMPLE/DOUBLE FR	EJE LENTO SENCILLO/DOBLE ES	EIXO DE SAÍDA SIMPLES/DUPLO PT

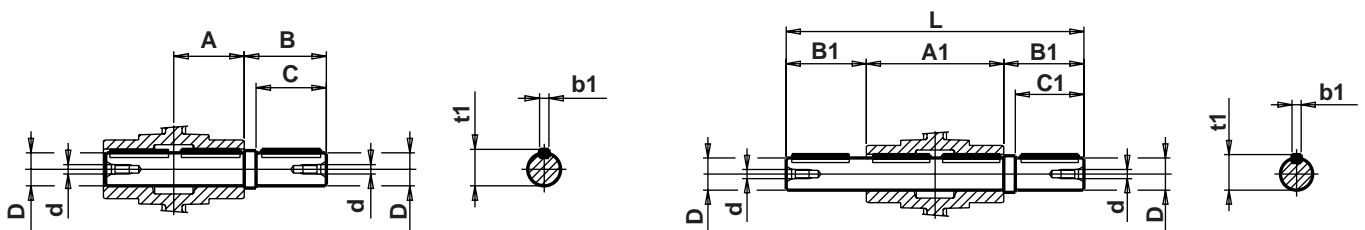

	A	A1	B	B1	C	C1	D h7	d	L	b1	t1
U-MU 30	28,5	57	35	35	30	30	14	M5	127	5	16
U-MU 40	39	78	43	43	40	40	18	M5	164	6	20,5
U-MU 50	46	92	53,5	53,5	50	50	25	M8	199	8	28
U-MU 63	56	112	65	53,5	60	50	25	M8	219	8	28
U-MU 75	60	120	70	63,5	60	60	28	M8	247	8	31
U-MU 90	70	140	65	84,5	60	80	35	M8	309	8	38
U-MU 110	77,5	155	126	84,5	110	80	42	M10	324	12	45

BRACCIO DI REAZIONE

IT

TORQUE ARM

EN

DREHMOMENTSTUTZEN

DE

BRAS DE RÉACTION

FR

BRAZO DE REACCION

ES

BRAÇO DE TRAÇÃO

PT

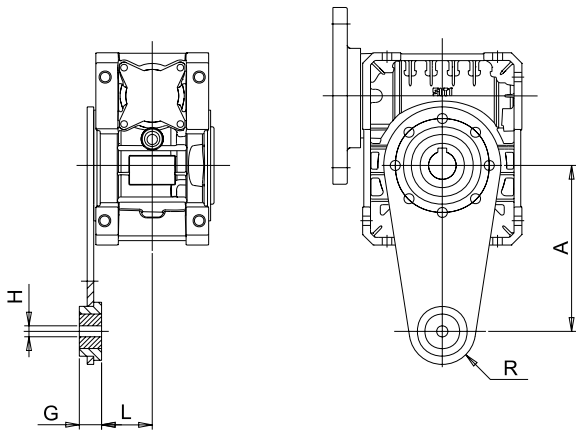

	A	L	G	H	R
MU 30	85	26,5	12,5	8	12,4
MU 40	100	29,5	20	10	30
MU 50	100	35,5	20	10	36
MU 63	150	46	20	10	30
MU 75	200	47,5	25	14	37,5
MU 90	200	57,5	25	14	37,5
MU 110	250	64,5	25	14	37,5

COPERCHIO DI PROTEZIONE

IT

PROTECTIVE COVER

EN

SCHUTZABDECKUNG

DE

COUVERCLE DE PROTECTION

FR

TAPA DE PROTECCIÓN

ES

TAMPA DE PROTEÇÃO

PT

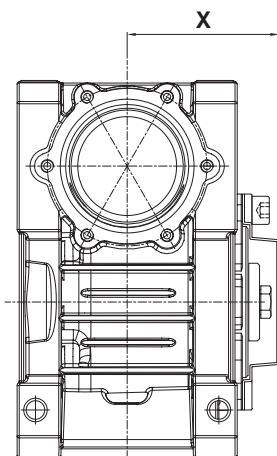

	X
MU 40	53
MU 50	60
MU 63	70,5
MU 75	75
MU 90	86
MU 110	94

Компания Редуктор

Г. Нижний Новгород, ул. Зайцева 31, оф. 508

Тел./факс +7 (831) 223-81-81

E-mail: info@reduktor.nnov.ru

Сайт: www.siti-reduktor.ru